

pool design

2023

CATALOGO > CATALOGUE



POP!

il tuo specchio d'acqua / your own pool

PISCINE
LAGHETTO®

POP!

2023

> CATALOGO

> CATALOGUE

> INDICE > INDEX

	PAGINA
UNA STORIA DI FAMIGLIA A family history	2
PRESENTAZIONE GAMMA POP Pop Pools presentation	8
PISCINA FUORITERRA POP! Pop! above-ground pool	18
PISCINA FUORITERRA CRYSTAL POP! Crystal Pop! above-ground pool	24
ACCESSORI Accessories	28
PESI E MISURE Weights and sizes	30
ALLEGATI TECNICI Technical drawings	31
GARANZIA E CONDIZIONI GENERALI DI VENDITA Warranty and general conditions of sale	33

PISCINE
LAGHETTO[®]
a FLUIDRA company



Agrisilos Srl si riserva il diritto di apportare modifiche senza obbligo di preavviso.

I prodotti illustrati in questo catalogo sono solo per uso privato.

Immagini non contrattuali.

Attenzione: I colori indicati in questo listino hanno la sola finalità di illustrare il prodotto. Non si riferiscono ad un colore specifico, pertanto si consiglia di visionare e far visionare direttamente i prodotti e/o i campioni di materiale e tessuto originali Piscine Laghetto.

VIETATA LA RIPRODUZIONE ANCHE PARZIALE DEL PRESENTE CATALOGO

Agrisilos Srl reserves the right to change specifications without prior notice or obligation.

The products shown in this catalogue are for private use only.

Images are not contractual.

Attention: Colors shown in this price list are for product description and illustration only.

They do not refer to a specific color, therefore it is advisable to show and/or directly view the products and/or samples of Piscine Laghetto original materials and fabrics.

ALL RIGHTS RESERVED

PISCINE
LAGHETTO[®]Laghetto
PISCINE

La storia di Piscine Laghetto inizia in un'afosa estate cremonese: era il 1974 e nel cortile di Agrisilos, azienda produttrice di teli per l'agricoltura, compariva una piscina tonda in telo gommato con anello gonfiabile per i bambini dei titolari, che potevano giocare e rinfrescarsi nella calda estate padana.

“LE GRANDI IDEE SPESSO NASCONO DAL CASO”

Era appena stata creata la prima Laghetto.

Un'idea semplice che si rivelò fin dall'inizio vincente, attirando immediatamente l'attenzione di tutti, tanto che venne subito depositato il brevetto n° 168558.

Erano anni di benessere e crescita economica e l'idea di una piscina da giardino facile da realizzare, bella e durevole conquistò il pubblico a tal punto che in poco tempo Piscine Laghetto diventò il brand di riferimento per le piscine residenziali fuori terra.

Quella di Piscine Laghetto è una storia di successo, di grandi intuizioni, progetti sempre nuovi ed all'avanguardia, caratterizzati dall'attenzione alla qualità ed all'assistenza, senza mai perdere di vista lo stile ed il design italiani.

Con la sua vasta gamma di prodotti caratterizzati da un design unico e inconfondibile e in quasi 50 anni di storia Piscine Laghetto è entrata nelle case e nei giardini di 250.000 famiglie in tutto il mondo.



“GREAT IDEAS OFTEN ARISE BY CHANCE”

The story of Piscine Laghetto began in a muggy Cremona summer: it was 1974 and in the courtyard of Agrisilos, a company producing tarpaulins for agriculture, a round rubberised sheet swimming pool with an inflatable ring appeared for fun to let the owners' children play and cool off in the heat of the Po Valley summer.

The first Laghetto had just been created.

A simple but winning idea has drawn everyone's attention, to such an extent that patent No. 168558 was immediately filed.

Those were years of prosperity and economic growth and the idea of a garden swimming pool that was easy to build, beautiful and durable won over the public: in a short time Piscine Laghetto became the reference brand for above ground residential swimming pools.

The Piscine Laghetto story is a story of success, of great intuition, always new and avant-garde projects, characterised by attention to quality and service, without ever losing sight of Italian style and design.

During the last 50 years Piscine Laghetto has entered the homes and gardens of 250,000 families all over the world with its vast range of products characterised by a unique and unmistakable design.



1974

CLASSIC

ANNI 80'

BLUESPRING

ANNI 90'

DOLCEVITA

2007

POP!

2014

PLAYA

2014

PISCINE LAGHETTO® da sempre si distingue per la capacità di cogliere ed anticipare le tendenze e le aspettative dei suoi clienti, cercando di proporre prodotti tecnicamente eccellenti ed allo stesso tempo iconici e di design.

Il servizio di assistenza dopo la vendita è un'altra delle priorità dell'azienda, perché chi sceglie un prodotto Laghetto possa godersi la propria piscina in modo semplice, sicuro, senza pensieri fin dal primo giorno.

Dal 2017 Agrisilos – Piscine Laghetto è entrata a far parte del **GRUPPO FLUIDRA**, gruppo multinazionale spagnolo quotato in Borsa, leader su scala mondiale nel settore della piscina e del benessere, che nel 2019 è entrato in IBEX 35, la lista delle 35 aziende più capitalizzate di Spagna.



Piscine Laghetto® has always stood out for its ability to understand and anticipate the trends and expectations of its customers, striving to offer products that are technically excellent and at the same time iconic and design-oriented.

The after-sales service is another of the company's priorities, so that those who choose a Laghetto product can enjoy their pool easily, safely and without worries from day one.

Since 2017, Agrisilos - Piscine Laghetto has become part of the Fluidra Group, a listed Spanish multinational group, world leader in the pool and wellness sector, which in 2019 entered IBEX 35, the list of the 35 most capitalised companies in Spain.



il nostro focus è la qualità!

> **QUALITY IS OUR FOCUS!**

The production department of Agrisilos has always been located in the plant of Vescovato (CR). Here the company covers a total area of around 10,000 square metres, in which the production area, part of the warehouse and the offices are located.

In 2018 the company obtained ISO 9001:2015 certification for production and design processes, also thanks to the introduction of the Lean method, which streamlines and optimises production times and processes.

In order to offer the best service to its customers, Agrisilos has recently invested in the expansion of the storage and shipping area, which will allow us to be more reliable and punctual during high season.



FLUIDRA

PISCINE
LAGHETTO

2017

2021

2022

2022

2022

DIVINA

PLAYA TWIN

CRYSTAL
POP!

INFINITY DIVINA

"Siamo consapevoli di creare nuovi mondi e nuovi concetti di stile".

Fin dalla nascita del marchio, Piscine Laghetto è stata dirompente nel mondo della piscina e non solo.

Il forte DNA italiano fatto di arte, cultura, design e genialità si ritrova nella progettazione di tutti i prodotti.

La creatività dell'azienda ha portato negli anni ad un "upgrade" del prodotto stesso, riqualificandolo e rinnovandolo in termini di design, immagine e mercato di riferimento.

Per Piscine Laghetto la piscina diventa così un oggetto di arredo che si inserisce piacevolmente nel giardino, sotto un portico, in una terrazza o anche all'interno della casa.

Un nuovo concetto di "arredare con l'acqua" si impone con la sua originalità, eleganza ed unicità e proietta l'essenza del prodotto al di fuori del mondo piscina.

Non solo un oggetto estivo da presentare per completare un ambiente outdoor, ma il cuore di un progetto innovativo di design e di arredo che diventa trasversale a tutte le stagioni e a tutti gli ambienti.



"We are conscious of creating new worlds and new styles".

Since the birth of the brand, Piscine Laghetto has been disruptive in the swimming pool world and beyond.

The strong Italian DNA of art, culture, design and geniality can be found in the design of all products.

Over the years, the company's creativity has led to an upgrade and renewal of the product itself, in terms of design, image and target market.

The swimming pool becomes a piece of furniture that fits pleasantly into the garden, a porch, a terrace or even inside the home.

A new concept of "furnishing with water" imposes itself with its originality, elegance and uniqueness, projecting the essence of the product outside the pool world.

The pool becomes not just a summer object that completes an outdoor environment, but the heart of an innovative design and furnishing project.

This way it becomes transversal to all seasons and environments.



Questo nuovo modo di concepire il prodotto è frutto di anni di attiva presenza alle principali fiere del settore arredamento, eventi Fuorisalone del Mobile con importanti installazioni avveniristiche e cooperazioni prestigiose, fino alla significativa apertura di uno Showroom a Milano Brera, punto di riferimento e cuore del Design internazionale.

L'ingresso dell'azienda nel gruppo multinazionale spagnolo Fluidra ha permesso di ampliare i suoi mercati di riferimento su scala mondiale, senza mai perdere la propria **italianità, da sempre l'essenza di Piscine Laghetto.**

La nostra anima è tutta italiana!
> OUR SOUL IS ALL ITALIAN!

This new way of conceiving the product is the result after years of active presence at the main furnishing sector fairs, Fuorisalone del Mobile events with important futuristic installations and prestigious co-operations, up to the significant opening of a Showroom in Milano Brera, a reference point and heart of the international Design.

The company's entry into the Spanish multinational group Fluidra has allowed it to expand its reference markets on a global scale, without ever losing **the distinctive Italian character that is the essence of Piscine Laghetto.**



POP!

LA COLLEZIONE MODA LAGHETTO
THE LAGHETTO FASHION COLLECTION



LA COLLEZIONE MODA LAGHETTO

POP! è la gamma di piscine fuori terra con cui Laghetto ha voluto festeggiare nel 2014 i primi 40 anni di attività. Figlia di quattro decenni di brevetti e progetti innovativi, Pop! è oggi massima espressione qualitativa e prodotto di riferimento nel suo settore di mercato.

Una gamma che strizza l'occhio alla moda, presentandosi con stile in un ventaglio di possibilità tra colori pastello, tenui e freschi, per poter essere inserita brillantemente e in maniera anticonformista nel giardino di casa.

L'ultima arrivata in casa Pop! è **CRYSTAL**, la cui novità è data da un gioco di finestrature e trasparenze che la rendono ancor più appariscente: il led interno, coadiuvato dalla particolare lavorazione del telo, crea scenografici giochi di luce anche di notte.



PISCINE LAGHETTO® a FLUIDRA company

THE LAGHETTO FASHION COLLECTION

Pop! is the range of above-ground pools with which Laghetto wanted to celebrate its first 40 years in business in 2014.

Daughter of four decades of patents and innovative designs, Pop! is today the highest expression of quality and a reference product in its market sector.

A range that winks at fashion, stylishly presenting itself in a range of possibilities between pastel, soft and fresh colours, so that it can be brilliantly and unconventionally inserted in the home garden.

The latest arrival in the Pop! house is **Crystal**, whose novelty lies in a play on windows and transparencies that make it even more striking: the internal LED, together with the special processing of the fabric, creates spectacular plays of light even at night.



CRYSTAL
POP!



POP!

COS'È POP ? > WHAT IS POP ?

POP! è una piscina autoportante creata dall'esperienza e dal design italiano. E' costituita da un liner altamente resistente alla trazione, sorretto da una struttura specificamente disegnata e progettata per sostenere la vasca in qualsiasi situazione di utilizzo.

POP! è completamente smontabile in tempi brevi (dalle 2 alle 6 ore). Inoltre, non essendo vincolata al terreno in nessun modo, non necessita di particolari preparazioni del terreno di appoggio, come pavimentazioni in cemento o altro tipo. È richiesta semplicemente un'area perfettamente piana e liscia su cui montarla.

POP! viene fornita completa di tavolette sottopiede stampate che consentono di ridistribuire uniformemente il peso della piscina su tutti i piedi del perimetro della vasca, stabilizzandola al meglio sui vari tipi di terreno.

Pop! is a self-supporting pool created by Italian experience and design. It consists of a highly tensile-resistant liner supported by a structure specifically designed and engineered to support the pool in any situation of use.

Pop! can be completely dismantled in a short time (2 to 6 hours). Moreover, as it is not bound to the ground in any way, it does not require any special preparation of the supporting ground, such as concrete or other types of flooring. All that is required is a perfectly flat and smooth area on which to install it.

Pop! is supplied complete with moulded footplates that allow the weight of the pool to be evenly redistributed over all the feet of the pool perimeter, stabilising it as best as possible on various types of ground.

POP! alla moda con colori e trasparenze
> TRENDY WITH COLOURS AND TRANSPARENCIES

Pop! è disponibile in 4 colori moda mentre la versione **Crystal Pop!** gioca con la trasparenza e due colori neutri.

Pop! is available in four fashionable colours while **Crystal Pop!** version plays with transparency and two neutral colours.

POP!

Tanto colore per dare stile al giardino di casa.

Lots of colour to give style to the home garden.



PAG 18

CRYSTAL POP!

Bella di giorno, spettacolare di notte.

Beautiful by day, spectacular by night.



PAG 24

POP!

PERCHÉ POP ? > WHY POP ?

Come rendere Classic, piscina fuoriterra #1, prodotto storico e iconico by Piscine Laghetto, sempre migliore?

Nasce Pop!, la fuoriterra morbida più performante sul mercato. Telo made in Italy con altissima resistenza, trattamento anti-UV e anti-invecchiamento.

Colori provocatori rendono Pop! unica e inimitabile, abbinando estetica ad una qualità costruttiva ineguagliabile.

L'anima fashion è completata dalla caratteristica etichetta rossa, la firma del mondo Pop!

How to make Classic, above-ground pool #1, historic and iconic product by Piscine Laghetto, always better?

By introducing Pop!, the best performing soft above-ground pool on the market. Pop! liner is made in Italy with high resistance, anti-UV and anti-ageing treatment. Provocative colours make Pop! unique and inimitable, combining aesthetics with unparalleled build quality. The Fashion mood is complemented by the characteristic red label, a signature of the Pop! world.

POP!
Tutte le dimensioni
ALL THE AVAILABLE SIZES

POP!					
MOD.	SPECCHIO D'ACQUA water size (m)	COLORI DISPONIBILI 2023 available colours	INGOMBRO CON SOTTOPIEDI (m) Overall sizes with foot supports	INGOMBRO SENZA SOTTOPIEDI (m) Overall sizes without foot supports	VOLUME (mc)
24	2,80 x 4,00 x h.1,2	● ● ●	3,84 x 5,04	3,60 x 4,80	13,5
25	2,80 x 5,30 x h.1,2	● ● ●	3,84 x 6,34	3,60 x 6,10	17
26	2,80 x 6,60 x h.1,2	● ● ●	3,84 x 7,64	3,60 x 7,40	21,5
27	2,80 x 7,80 x h.1,2	● ● ●	3,84 x 8,84	3,60 x 8,60	25
46	4,00 x 6,60 x h.1,2	● ● ●	5,04 x 7,64	4,80 x 7,40	30,5
47	4,00 x 7,80 x h.1,2	● ● ●	5,04 x 8,84	4,80 x 8,60	36
49	4,00 x 9,00 x h.1,2	● ● ●	5,04 x 10,04	4,80 x 9,80	41,5
510	5,30 x 10,25 x h.1,2	● ● ●	6,34 x 11,29	6,10 x 11,05	62,5
511	5,30 x 11,50 x h.1,2	● ● ●	6,34 x 12,54	6,10 x 12,30	70
612	6,60 x 12,70 x h.1,2	● ● ●	7,64 x 13,74	7,40 x 13,50	96,5

CRYSTAL POP!					
MOD.	SPECCHIO D'ACQUA water size (m)	COLORI DISPONIBILI 2023 available colours	INGOMBRO CON SOTTOPIEDI (m) Overall sizes with foot supports	INGOMBRO SENZA SOTTOPIEDI (m) Overall sizes without foot supports	VOLUME (mc)
24	2,80 x 4,00 x h.1,2	⊕ ⊕	3,84 x 5,04	3,60 x 4,80	13,5
25	2,80 x 5,30 x h.1,2	⊕ ⊕	3,84 x 6,34	3,60 x 6,10	17

measure indicative (non vincolanti) the measures are indicatives

TELO VASCA > POOL LINER



TESSUTO

I teli vasca Pop! vengono realizzati in tessuto Trevira spalmato da 1000 g/mq, prodotto esclusivo Piscine Laghetto.

Il liner Laghetto, membrana tensostrutturale altamente resistente alla trazione, viene successivamente trattato anti-UV con l'utilizzo di additivi speciali che limitano esponenzialmente l'invecchiamento del materiale.

Il telo Pop! viene testato per resistere alle più estreme prove di trazione (430 kg ogni 5 cm).

La grande esperienza di Piscine Laghetto nella produzione e nella lavorazione di teli specifici per piscine è sinonimo di assoluta qualità e affidabilità.

Quasi 50 anni di ricerca, sviluppo e di stretta collaborazione tra aziende accuratamente selezionate di fornitori di tessuti hanno portato alla formulazione di teli strutturalmente e chimicamente specifici per il settore delle piscine.

Le macchine saldatrici, cuore pulsante del reparto produttivo, sono state appositamente studiate e realizzate su disegno per rispondere alle esigenze tecnologiche produttive aziendali.

Ogni telo è quindi saldato per avere la massima resistenza alle varie sollecitazioni, donando così ai prodotti Laghetto il pregio e l'efficienza che li contraddistinguono e differenziano dal resto del mercato.

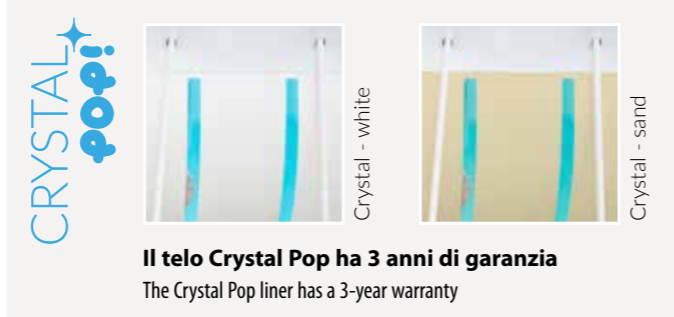
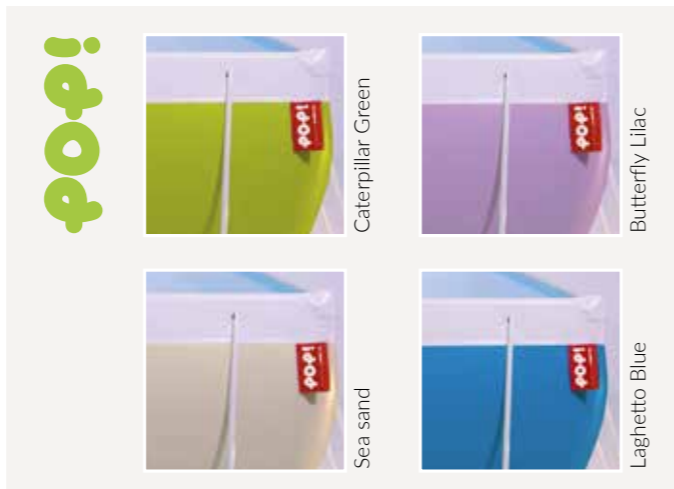

Il telo Crystal Pop ha 3 anni di garanzia
The Crystal Pop liner has a 3-year warranty

LINER

Pop! pool liner are made of coated Trevira fabric of 1000 g/m², an exclusive Piscine Laghetto product.

The Laghetto liner, a highly tensile-resistant membrane, is subsequently treated anti-UV with special additives that exponentially limit the ageing of the material.

The Pop! liner is tested to withstand the most extreme tensile tests (430 kg every 5 cm).

Piscine Laghetto's vast experience in the production and processing of specific pool liners is synonymous with absolute quality and reliability.

Almost 50 years of research, development and close collaboration between carefully selected companies of fabric suppliers have led to the formulation of sheets that are structurally and chemically specific for the swimming pool sector.

The welding machines, the beating heart of the production department, are specially designed and manufactured to meet the company's technological production requirements.

Each pool liner is then welded to have maximum resistance to various stresses, thus giving Laghetto products the quality and efficiency that distinguish and differentiate them from the rest of the market.

STRUTTURA > STRUCTURE



LA STRUTTURA

La struttura di Pop!, detta anche paleria, è costituita da una serie di tubolari in acciaio zincato sovraverniciato, studiati e realizzati appositamente per resistere alle più disparate esperienze di utilizzo.

Facili e intuitivi nel montaggio, il numero totale di tubolari varia in base alle dimensioni della piscina e in base al modello.

STRUCTURAL PARTS

The structure of Pop!, also known as "the poles", is made up of a series of overpainted galvanised steel tubulars, specially designed and manufactured to withstand a wide variety of uses.

Easy to assemble, the total number of tubulars varies according to the size and the model of the pool.

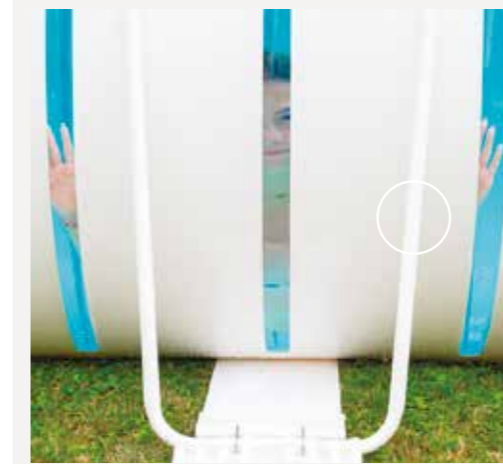

La struttura Crystal Pop ha 3 anni di garanzia
The Crystal Pop structure has a 3-year warranty

SOTTOPIEDI > FOOT SUPPORTS



SOTTOPIEDI

Ogni piscina Pop! (e Crystal Pop) è dotata delle esclusive tavolette sottopiede stampate in colore bianco, ideate dai nostri tecnici per la perfetta posa della piscina, anche su fondi non pavimentati.

Le tavolette sottopiede consentono di ridistribuire uniformemente il peso della piscina su tutti i piedi del perimetro della vasca, stabilizzandola al meglio su tutti i tipi di terreno e rendendo il montaggio versatile e veloce.

FOOT SUPPORTS

Every Pop! pool (and Crystal Pop) is equipped with the exclusive white-printed foot supports, designed by our technicians for a perfect pool installation, even on non-paved surfaces.

The foot supports allow the weight of the pool to be evenly redistributed over all the feet of the pool perimeter, stabilising it in the best way as possible on all types of ground, making installation versatile and fast.



Tutto è studiato nel dettaglio!

POP! EVERYTHING IS DESIGNED IN DETAIL!

SCALA > LADDER



SCALA DI SICUREZZA LAGHETTO

Piscine Laghetto ha introdotto nei primi anni 2000 la scala di sicurezza, studiata ad hoc dall'ufficio tecnico per le nostre piscine fuoriterza morbide e che, una volta fissata alla struttura della vasca, si stabilizza evitando così il ribaltamento in avanti o indietro dei bagnanti.

La parte esterna di sicurezza può essere sollevata verso l'alto e fissata con apposito cinghiolo alla parte alta della scala per impedire ai bambini di entrare in piscina nei momenti in cui non è possibile sorvegliarli.

La scala è realizzata con tubolari in acciaio zincato e verniciato e acciaio inox AISI304. I gradini e il balconcino superiore in plastica bianca ad alta resistenza e durata.

LAGHETTO SAFETY LADDER

Piscines Laghetto introduced the safety ladder in the early 2000s, specially designed by the technical department for our soft above-ground pools. Once it is fixed to the structure of the pool, it stabilises and prevent bathers from tipping backwards or forwards.

The external safety part can be lifted upwards and fixed with a special strap to the upper part of the ladder to prevent children from entering the pool when it is not possible to supervise them.

The ladder is made of power coated galvanized steel and AISI304 stainless steel tubulars. Steps and upper balcony are made in resistant and durable white plastic.

FARI A LED > LED SPOTS

FARI A LED BIANCHI

Ogni piscina Pop! prevede la fornitura di serie sul telo vasca di uno o due faretti a Led bianchi della linea Laghetto (a seconda della misura scelta) che donano alle vasche giochi di luce intensi, sia di giorno che di notte.

Nel modello **Crystal Pop** l'effetto in notturna è ancora più spettacolare grazie alla combinazione tra l'illuminazione e le fasce trasparenti laterali.

Questi fari uniscono un rendimento luminoso altamente performante, consumi elettrici ridotti (meno di 8 W) e una grande durata nel tempo.

Ciascun faretto è alimentato a 12V e viene fornito completo del relativo trasformatore da posizionare ad una distanza di 3,5 m dalla piscina.

WHITE LED SPOTS

Each Pop! pool includes one or two Laghetto white LED spotlights (depending on the size of the pool). They give the pools impressive light effects, both during the day and at night.

In the Crystal Pop model, the effect at night is even more spectacular thanks to the combination of lighting and transparent side strips.

These spotlights combine high-performance light output, low power consumption (less than 8 W) and great durability.

Each spotlight is powered at 12V and comes complete with its transformer to be positioned at a distance of 3.5 m from the pool.



SKIMMER > SKIMMER



SKIMMER LAGHETTO

Lo skimmer Piscine Laghetto è fissato alla parete della piscina, ha la testa flottante e lavora a sfioro sull'acqua, garantendone così un alto grado di pulizia costante nel tempo.

Dotato di cestello prefiltra, il suo pescaggio a 360 gradi permette la migliore pulizia possibile della piscina con performance superiori agli skimmer a parete.

L'escursione della testa flottante in altezza permette una grande flessibilità nel riempimento vasca, evitando che possa pescare aria e bloccare la pompa dell'impianto di filtrazione. Lo skimmer è inoltre dotato di una serie di accorgimenti anti-intrappolamento e anti-risucchio per la massima sicurezza di tutti i bagnanti.

LAGHETTO SKIMMER

The Piscine Laghetto skimmer is fixed to the pool wall, it has a floating head and works by skimming over the water, thus guaranteeing a high degree of constant cleanliness over time.

Equipped with a pre-filter basket, its 360-degree draught allows the best possible cleaning of the pool with superior performance to wall-mounted skimmers.

The excursion of the floating head in height allows great flexibility in filling the pool, preventing it from drawing air and blocking the filtration system pump. It is also equipped with a series of anti-trapping and anti-sucking devices for maximum safety of all bathers.



TUBAZIONI > PIPES

TUBAZIONI

Le tubazioni degli impianti di filtrazione sono un altro degli standard di qualità che caratterizzano i kit Piscine Laghetto.

Sono realizzate in tubo corrugato di PVC di colore bianco, altamente resistente e duraturo, con raccordi da un pollice e mezzo, montati a pressione e incollati in fabbrica per assicurare la migliore tenuta possibile nel tempo.

Le tubazioni, dotate di raccordi filettati e guarnizioni, vengono avvitate ai passanti della piscina e all'impianto di filtrazione, senza nessun tipo di fascetta.

PIPES

Filtration system piping is another of the quality standards that characterise Piscine Laghetto kits.

They are made of corrugated white PVC pipe, highly resistant and durable, with one-and-a-half inch fittings, pressure-fitted and glued at the factory to ensure the best possible seal over time.

The pipes, equipped with threaded fittings and gaskets, are screwed to the pool passages and the filtration system, without any type of clamping.

KIT ASPIRAFANGO > VACUUM CLEANER

KIT ASPIRAFANGO

La pulizia dell'acqua è fondamentale nella gestione della piscina.

Ogni kit piscina Pop! è dotato di un kit aspirafango per la pulizia del fondo, con la lunghezza della tubazione calibrata in base alla misura della vasca e al numero di skimmer installati.

VACUUM CLEANER

Cleaning your pool is essential.

Each Pop! pool kit is equipped with a vacuum pool cleaner kit to clean the bottom, with the length of the hose calibrated according to the size of the pool and the number of skimmers installed.

FILTRAZIONE > FILTRATION



FILTRAZIONE

Piscine Laghetto, facendo parte del Gruppo Fluidra, (azienda leader nel mondo per la fornitura di attrezzatura per le piscine), sfrutta l'esperienza della casa madre per equipaggiare le proprie vasche con **impianti di filtrazione e depurazione dall'indiscussa qualità costruttiva e dalle migliori performance sul mercato.**

Consapevoli dell'importanza della qualità dell'acqua, gli impianti di filtrazione Pop! sono adeguatamente dimensionati per garantire il massimo grado di pulizia e igiene.

Per Pop! è disponibile il sistema di filtrazione a sabbia declinabile nelle versioni da 6, 10 o 15 m³/h.

FILTRATION

As part of the Fluidra Group, one of the world's leading suppliers of swimming pool equipment, Piscine Laghetto takes advantage of the parent company's experience to equip its pools with filtration and purification systems of undisputed construction quality and top market performance.

Aware of the importance of water quality Pop's filtration systems are adequately dimensioned to guarantee maximum cleanliness and hygiene.

A sand filtration system is available for Pop! in 6, 10 or 15 m³/h versions.



	FILTRO / FILTER		POMPA / PUMP						
	n° skimmer skimmer	n° mandate outlet	tipo type	carico sabbia sand load	prefiltro prefilter	portata max max flow rate	potenza power	prevalenza max max prevalence	rumorosità max max noise
	1	1	filtro a sabbia Cantabric Ø400 mm stampato ad iniezione con valvola top a 6 vie. Cantabric Ø400 mm injection-moulded sand filter with 6-way top valve	60 Kg	si yes	15 m ³ /h	0.73 kW	9 m	73 db
	1	1	filtro a sabbia Cantabric Ø500 mm stampato ad iniezione con valvola top a 6 vie. Cantabric Ø500 mm injection-moulded sand filter with 6-way top valve	100 Kg	si yes	19 m ³ /h	0.77 kW	13,1 m	78 db
	2	2	filtro a sabbia Cantabric Ø600 mm stampato ad iniezione con valvola top a 6 vie Cantabric Ø600 mm injection-moulded sand filter with 6-way top valve	150 Kg	si yes	22 m ³ /h	1.1 kW	16 m	78 db

GLI ACCESSORI

> ACCESSORIES



COPRIPISCINA

> POOL COVER

OPTIONAL



COPRIPISCINA INVERNALE

Il telo di copertura invernale Light System Plus (di colore verde/nero) con tiranti elastici permette la chiusura ermetica della piscina per tutti i mesi in cui non viene utilizzata. L'utilizzo del copripiscina, unitamente all'uso di corretti prodotti chimici, permette la giusta conservazione dell'acqua contenuta in vasca.

WINTER POOL COVER

The pool winter cover "Light System Plus" (in green/black colors) is equipped with elastic cords rod that allow to close hermetically the pool when not in use. This accessory, jointly with correct chemical products, preserves the water status during winter period.

OPTIONAL



COPRIPISCINA ESTIVO

Il telo di copertura isotermico permette di ridurre lo scambio di calore giorno/notte e di conservare meglio la temperatura accumulata durante il giorno. Può essere lasciato galleggiare sullo specchio d'acqua anche durante il giorno, dato che il materiale permette il passaggio dei raggi solari. Questo telo di copertura viene fornito bordato.

SUMMER POOL COVER

The isothermal cover reduces the day/night heat exchange and helps to maintain the water temperature. It can be left floating on the water during the day, because its fabric allows sunlight to pass through. Isothermal cover for Pop! pool is edged for a better finish.

PAG 28

> I KIT POP!

> THE KITS

PAG 18



PAG 24



*Tutta la magia di Pop!
per misura, colore
e trasparenze*

ALL THE MAGIC OF POP!
IN SIZE, COLOUR
AND TRANSPARENCIES

I KIT POP! > THE KITS

**KIT PISCINA
POOL KIT**

=
1 + 2 + 3 + 4 + 5 +
6 + 7 + 8



1
Telo vasca. Pool liner.

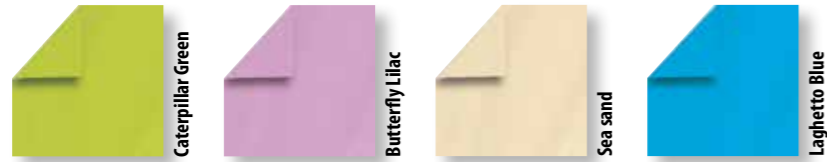

2
Struttura piscina (paleria).
Structural parts (poles).

3
Tavolette sottopiede.
Pool foot support.



4
Skimmer brevettato Piscine Laghetto.
Patented Piscine Laghetto skimmer.

5
impianto di filtrazione a sabbia
(come da tabella).
**ATTENZIONE: L'IMPIANTO DI FILTRAZIONE
NON COMPRENDE IL QUADRO ELETTRICO.**
Sand Filtration System (as in the diagram).
Attention: the filtration system doesn't include the
switchboard.



6
Scala di sicurezza.
Safety ladder.



7
Faretto a Led ad alta resa luminosa:
n. 1 faretto sino alla misura 47
n. 2 faretti dalla misura 49
(posizione standard - v. pag. 31).
High brightness LED spotlight:
n. 1 Spot until model 47 / n. 2 Spots from model 49
(standard placement - see page 31).



8
Sistema aspirafango per pulizia fondo.
(m. tubazioni come da tabella).
Vacuum cleaner system.
(m. piping as per table).



Copripiscina invernale
Winter pool cover



OPTIONAL

Copripiscina isothermico galleggiante
Isothermal floating pool covers



OPTIONAL

PAG 28

MOD. / DIMENSIONE
MOD. / SIZES

IMPIANTO DI FILTRAZIONE / FILTERING SYSTEM

COLORE / COLOUR

CODICE / CODE

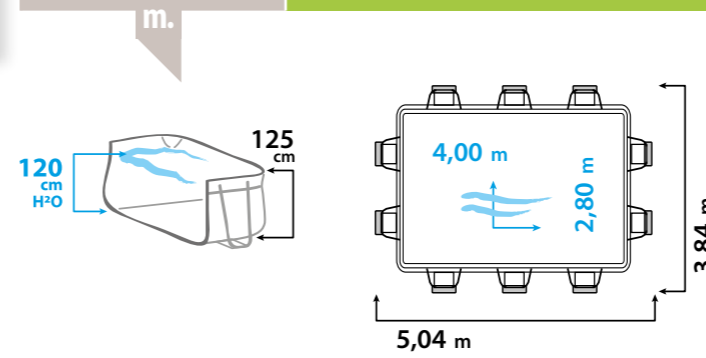

24

2,80 x 4,00
h.1,20 m



SABBIA* DA 6 m³ h - 1 SKIMMER
1 SKIMMER 6 m³ h SAND FILTERING SYSTEM



Caterpillar green



KITPOP24MLS6

Butterfly lilac



KITPOP24LVS6

Sea sand



KITPOP24CRS6



SABBIA* DA 10 m³ h - 1 SKIMMER
1 SKIMMER 10 m³ h SAND FILTERING SYSTEM



Caterpillar green



KITPOP24MLS

Butterfly lilac



KITPOP24LVS

Sea sand



KITPOP24CRS

MISURE INDICATIVE, NON VINCOLANTI, TOLLERANZA ± 10 CM.
THE MEASURES ARE INDICATIVE, TOLERANCE ± 10 CM.

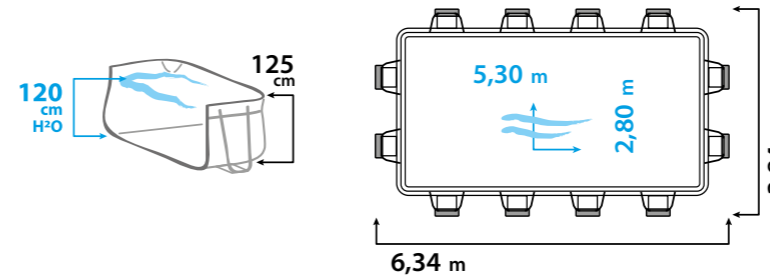

25

2,80 x 5,30
h.1,20 m



SABBIA* DA 6 m³ h - 1 SKIMMER
1 SKIMMER 6 m³ h SAND FILTERING SYSTEM



Caterpillar green



KITPOP25MLS6

Butterfly lilac



KITPOP25LVS6

Sea sand



KITPOP25CRS6



SABBIA* DA 10 m³ h - 1 SKIMMER
1 SKIMMER 10 m³ h SAND FILTERING SYSTEM



Caterpillar green



KITPOP25MLS

Butterfly lilac



KITPOP25LVS

Sea sand



KITPOP25CRS

MISURE INDICATIVE, NON VINCOLANTI, TOLLERANZA ± 10 CM.
THE MEASURES ARE INDICATIVE, TOLERANCE ± 10 CM.

* La sabbia del depuratore è esclusa | Sand is not included

MOD. / DIMENSIONE
MOD. / SIZES

IMPIANTO DI FILTRAZIONE / FILTERING SYSTEM

COLORE / COLOUR

CODICE / CODE

POP!

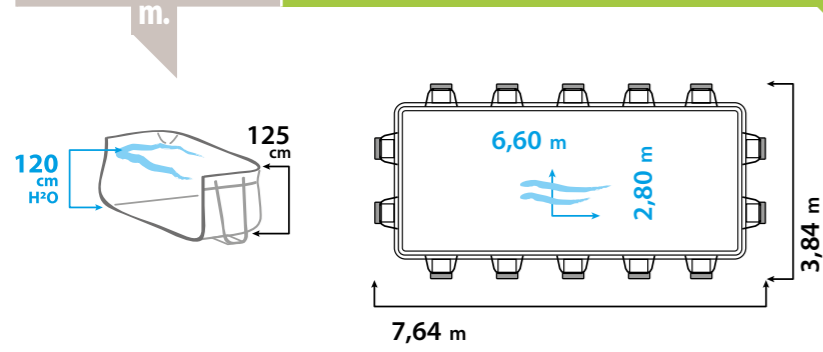

MISURE INDICATIVE, NON VINCOLANTI, TOLLERANZA ± 10 CM.
THE MEASURES ARE INDICATIVE, TOLERANCE ± 10 CM.

26

2,80 x 6,60
h.1,20 m



SABBIA* DA 6 m³ h - 1 SKIMMER
1 SKIMMER 6 m³ h SAND FILTERING SYSTEM



Caterpillar green



KITPOP26MLS6

Butterfly lilac



KITPOP26LVS6

Sea sand



KITPOP26CRS6



SABBIA* DA 10 m³ h - 1 SKIMMER
1 SKIMMER 10 m³ h SAND FILTERING SYSTEM



Caterpillar green



KITPOP26MLS

Butterfly lilac



KITPOP26LVS

Sea sand



KITPOP26CRS

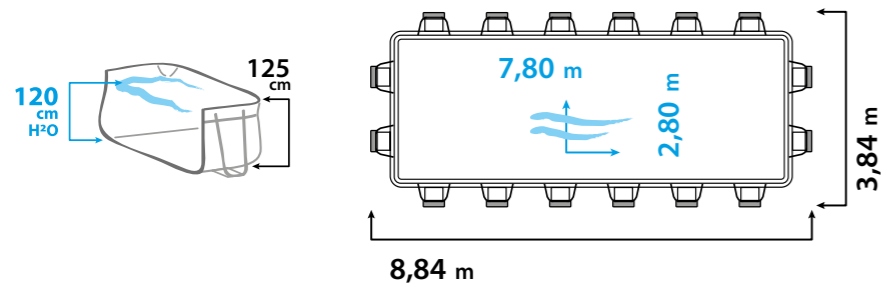

MISURE INDICATIVE, NON VINCOLANTI, TOLLERANZA ± 10 CM.
THE MEASURES ARE INDICATIVE, TOLERANCE ± 10 CM.

27

2,80 x 7,80
h.1,20 m



SABBIA* DA 10 m³ h - 1 SKIMMER
1 SKIMMER 10 m³ h SAND FILTERING SYSTEM



Caterpillar green



KITPOP27MLS

Butterfly lilac



KITPOP27LVS

Sea sand



KITPOP27CRS

MOD. / DIMENSIONE
MOD. / SIZES

IMPIANTO DI FILTRAZIONE / FILTERING SYSTEM

COLORE / COLOUR

CODICE / CODE

POP!

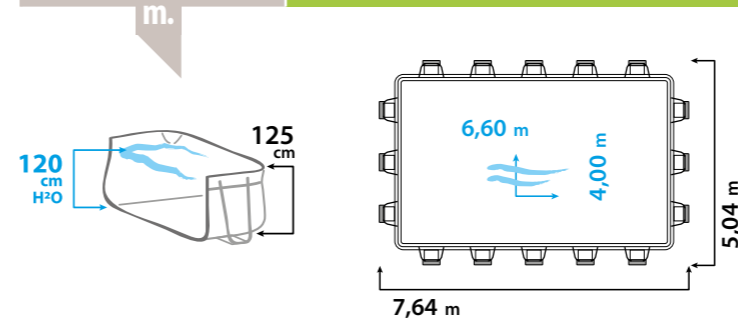

MISURE INDICATIVE, NON VINCOLANTI, TOLLERANZA ± 10 CM.
THE MEASURES ARE INDICATIVE, TOLERANCE ± 10 CM.

46

4,00 x 6,60
h.1,20 m



SABBIA* DA 10 m³ h - 1 SKIMMER
1 SKIMMER 10 m³ h SAND FILTERING SYSTEM



Caterpillar green



KITPOP46MLS

Butterfly lilac



KITPOP46LVS

Sea sand



KITPOP46CRS

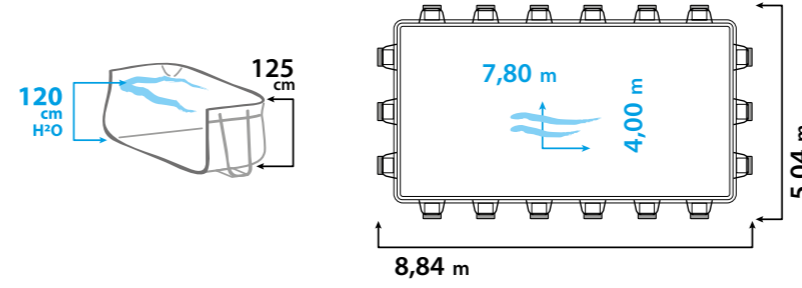

MISURE INDICATIVE, NON VINCOLANTI, TOLLERANZA ± 10 CM.
THE MEASURES ARE INDICATIVE, TOLERANCE ± 10 CM.

47

4,00 x 7,80
h.1,20 m



SABBIA* DA 10 m³ h - 1 SKIMMER
1 SKIMMER 10 m³ h SAND FILTERING SYSTEM



Caterpillar green



KITPOP47MLS

Butterfly lilac



KITPOP47LVS

Sea sand



KITPOP47CRS

MOD. / DIMENSIONE
MOD. / SIZES

IMPIANTO DI FILTRAZIONE / FILTERING SYSTEM

COLORE / COLOUR

CODICE / CODE

POP!

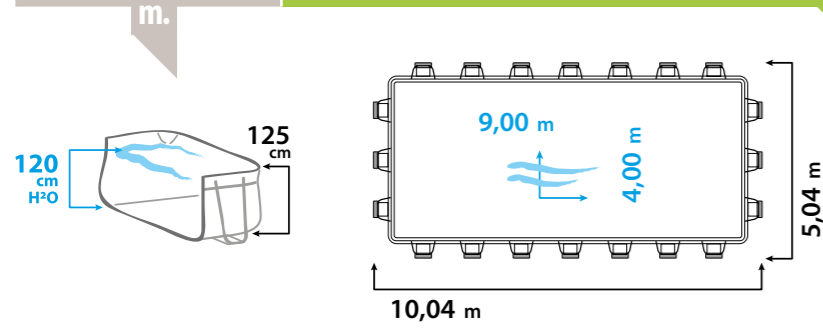

MISURE INDICATIVE, NON VINCOLANTI, TOLLERANZA ± 10 CM.
THE MEASURES ARE INDICATIVE, TOLERANCE ± 10 CM.

49

4,00 x 9,00
h.1,20 m



SABBIA* DA 15 m³ h - 2 SKIMMER
2 SKIMMERS 15 m³ h SAND FILTERING SYSTEM



Sea sand



KITPOP49CRGS

Laghetto blue



KITPOP49BLGS

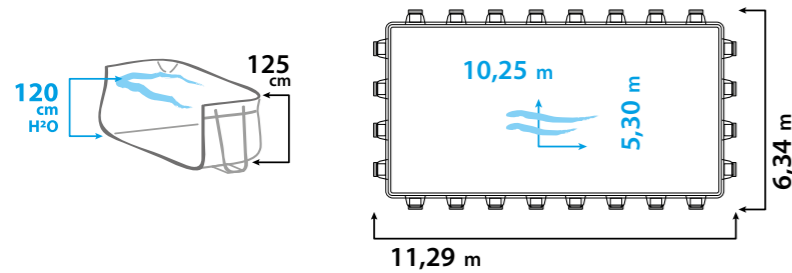

MISURE INDICATIVE, NON VINCOLANTI, TOLLERANZA ± 10 CM.
THE MEASURES ARE INDICATIVE, TOLERANCE ± 10 CM.

510

5,30 x 10,25
h.1,20 m



SABBIA* DA 15 m³ h - 2 SKIMMER
2 SKIMMERS 15 m³ h SAND FILTERING SYSTEM



Sea sand



KITPOP510CRGS

Laghetto blue



KITPOP510BLGS

MOD. / DIMENSIONE
MOD. / SIZES

IMPIANTO DI FILTRAZIONE / FILTERING SYSTEM

COLORE / COLOUR

CODICE / CODE

POP!

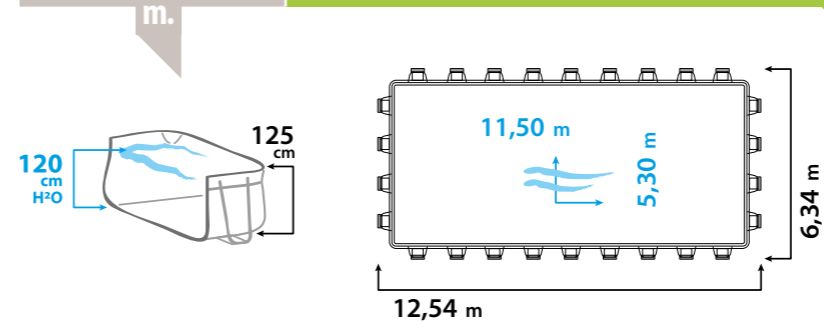

MISURE INDICATIVE, NON VINCOLANTI, TOLLERANZA ± 10 CM.
THE MEASURES ARE INDICATIVE, TOLERANCE ± 10 CM.

511

5,30 x 11,50
h.1,20 m



SABBIA* DA 15 m³ h - 2 SKIMMER
2 SKIMMERS 15 m³ h SAND FILTERING SYSTEM



Sea sand



KITPOP511CRGS

Laghetto blue



KITPOP511BLGS

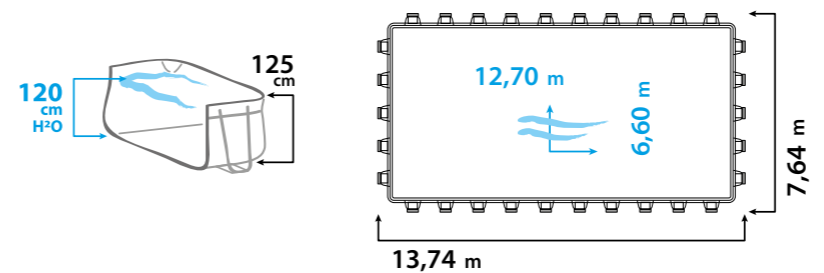

MISURE INDICATIVE, NON VINCOLANTI, TOLLERANZA ± 10 CM.
THE MEASURES ARE INDICATIVE, TOLERANCE ± 10 CM.

612

6,60 x 12,70
h.1,20 m



SABBIA* DA 15 m³ h - 2 SKIMMER
2 SKIMMERS 15 m³ h SAND FILTERING SYSTEM



Sea sand



KITPOP612CRGS

Laghetto blue



KITPOP612BLGS

* La sabbia del depuratore è esclusa | Sand is not included

* La sabbia del depuratore è esclusa | Sand is not included

CRYSTAL POP!

LA TRASPARENZA È DI MODA
TRANSPARENCY IS FASHION



LA TRASPARENZA È DI MODA

CRYSTAL POP! è l'ultima nata della famiglia Pop! di cui ne condivide l'attitudine fashion e l'ineguagliabile qualità strutturale e tecnologica Piscine Laghetto.

La trasparenza è un gioco divertente che di giorno permette di guardare dentro / fuori la vasca.

Di notte Crystal Pop! diventa scenografica e ancora più spettacolare grazie alla combinazione di finestrate trasparenti e la luce interna a Led bianca.

Crystal Pop! è perfetta per rendere speciale il giardino di casa anche di notte.



PISCINE LAGHETTO® a FLUIDRA company

TRANSPARENCY IS FASHION

Crystal Pop! is the latest addition to the Pop! family, sharing its fashionable attitude and unparalleled structural and technological quality by Piscine Laghetto.

Transparency is a fun game during the day, allowing you to look inside/outside the pool.

At night Crystal Pop! becomes scenic and even more spectacular thanks to the combination of the transparent windows and the white LED interior light.

Crystal Pop! is perfect for making your garden special even at night.

Day & night



CRYSTAL POP!

KIT PISCINA POOL KIT

=
1 + 2 + 3 + 4 + 5 +
6 + 7 + 8



1
Telo vasca. Pool liner.



8
Sistema aspirafango per pulizia fondo.
(m. tubazioni come da tabella).
Vacuum cleaner system.
(m. piping as per table).



2
Struttura piscina (paleria).
Structural parts (poles).

6
Scala di sicurezza.
Safety ladder.



Copripiscina invernale
Winter pool cover



3
Tavolette sottopiede.
Pool foot support.



4
Skimmer brevettato Piscine Laghetto.
Patented Piscine Laghetto skimmer.

7
n. 1 Faretto a Led ad alta resa luminosa
(posizione standard - v. pag. 31).
n. 1 High brightness LED spotlight:
(standard placement - see page 31).



Copripiscina isothermico galleggiante
Isothermal floating pool covers



5
impianto di filtrazione a sabbia
(come da tabella).
**ATTENZIONE: L'IMPIANTO DI FILTRAZIONE
NON COMPRENDE IL QUADRO ELETTRICO.**

Sand Filtration System (as in the diagram).
Attention: the filtration system doesn't include the
switchboard.



PAG 28

CRYSTAL POP!

MOD. / DIMENSIONE
MOD. / SIZES

IMPIANTO DI FILTRAZIONE / FILTERING SYSTEM

COLORE / COLOUR

CODICE / CODE

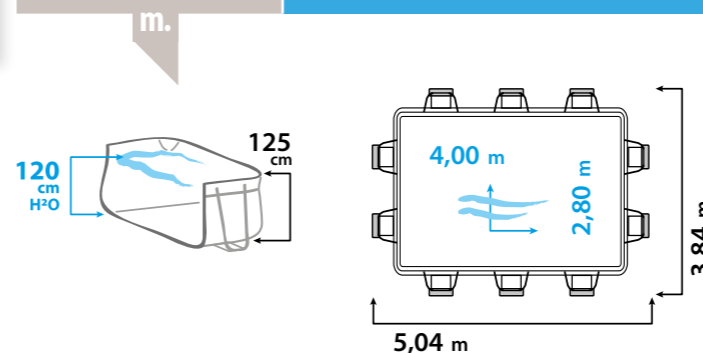

24

2,80 x 4,00
h.1,20 m

CRYSTAL
popi

6
SABBIA* DA 6 m³ h - 1 SKIMMER
1 SKIMMER 6 m³ h SAND FILTERING SYSTEM



Crystal white



KITCRYS24BIS6

Crystal sand



KITCRYS24BES6

MISURE INDICATIVE, NON VINCOLANTI, TOLLERANZA ± 10 CM.
THE MEASURES ARE INDICATIVE, TOLERANCE ± 10 CM.

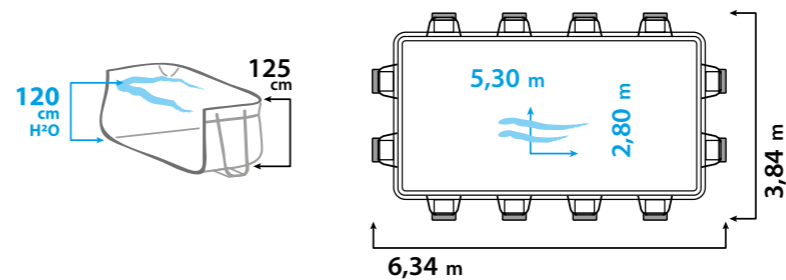

25

2,80 x 5,30
h.1,20 m

CRYSTAL
popi

6
SABBIA* DA 6 m³ h - 1 SKIMMER
1 SKIMMER 6 m³ h SAND FILTERING SYSTEM



Crystal white



KITCRYS25BIS6

Crystal sand



KITCRYS25BES6

MISURE INDICATIVE, NON VINCOLANTI, TOLLERANZA ± 10 CM.
THE MEASURES ARE INDICATIVE, TOLERANCE ± 10 CM.

* La sabbia del depuratore è esclusa | Sand is not included

> GLI ACCESSORI

> ACCESSORIES

OPTIONAL

ACCESSORI
ACCESSORIES **2** years
WARRANTY

COPERTURA INVERNALE WINTER POOL COVER

OPTIONAL

CHE COSA È ?

Il telo di copertura invernale Light System Plus con tiranti elastici, di colore verde/nero, permette la chiusura ermetica della piscina per tutti i mesi in cui la piscina non viene utilizzata.

L'utilizzo del copripiscina, unitamente all'uso di corretti prodotti chimici, permette la giusta conservazione dell'acqua contenuta in vasca.

WHAT IS IT ?

The pool winter cover "Light System Plus" (in green/black colors) is equipped with elastic cords rod that allow to close hermetically the pool when not in use.

This accessory, jointly with correct chemical products, preserves the water status during winter period.

PISCINA POOL	DESCRIZIONE DESCRIPTION	CODICE CODE
24 POP! CRYSTAL POP!	TELO DI COPERTURA INVERNALE LSP CON TIRANTI ELASTICI LSP WINTER POOL COVER COMPLETE WITH ELASTIC CORDS AND FIXATIONS	COT24
25 POP! CRYSTAL POP!	TELO DI COPERTURA INVERNALE LSP CON TIRANTI ELASTICI LSP WINTER POOL COVER COMPLETE WITH ELASTIC CORDS AND FIXATIONS	COT25
26	TELO DI COPERTURA INVERNALE LSP CON TIRANTI ELASTICI LSP WINTER POOL COVER COMPLETE WITH ELASTIC CORDS AND FIXATIONS	COT26
27	TELO DI COPERTURA INVERNALE LSP CON TIRANTI ELASTICI LSP WINTER POOL COVER COMPLETE WITH ELASTIC CORDS AND FIXATIONS	COT27
46	TELO DI COPERTURA INVERNALE LSP CON TIRANTI ELASTICI LSP WINTER POOL COVER COMPLETE WITH ELASTIC CORDS AND FIXATIONS	COT46
47	TELO DI COPERTURA INVERNALE LSP CON TIRANTI ELASTICI LSP WINTER POOL COVER COMPLETE WITH ELASTIC CORDS AND FIXATIONS	COT47
49	TELO DI COPERTURA INVERNALE LSP CON TIRANTI ELASTICI LSP WINTER POOL COVER COMPLETE WITH ELASTIC CORDS AND FIXATIONS	COT49
510	TELO DI COPERTURA INVERNALE LSP CON TIRANTI ELASTICI LSP WINTER POOL COVER COMPLETE WITH ELASTIC CORDS AND FIXATIONS	COT510
511	TELO DI COPERTURA INVERNALE LSP CON TIRANTI ELASTICI LSP WINTER POOL COVER COMPLETE WITH ELASTIC CORDS AND FIXATIONS	COT511
612	TELO DI COPERTURA INVERNALE LSP CON TIRANTI ELASTICI LSP WINTER POOL COVER COMPLETE WITH ELASTIC CORDS AND FIXATIONS	COT612

COPERTURA ESTIVA SUMMER POOL COVER

OPTIONAL

CHE COSA È ?

Il telo di copertura isoteramico permette di ridurre lo scambio di calore giorno/notte e di conservare meglio la temperatura accumulata durante il giorno. Può essere lasciato galleggiare sullo specchio d'acqua anche durante il giorno, dato che il materiale permette il passaggio dei raggi solari.

Questo telo di copertura viene fornito bordato.

WHAT IS IT ?

The isothermal cover reduces the day/night heat exchange and helps to maintain the water temperature.

It can be left floating on the water during the day, because its fabric allows sunlight to pass through.

Isothermal cover for Pop! is edged for a better finish.

PISCINA POOL	DESCRIZIONE DESCRIPTION	CODICE CODE
24 POP! CRYSTAL POP!	COPERTURA ESTIVA ISOTERMICA GALLEGGIANTE BORDATA FLOATING ISOTHERMAL SUMMER POOL COVER	COGI24
25 POP! CRYSTAL POP!	COPERTURA ESTIVA ISOTERMICA GALLEGGIANTE BORDATA FLOATING ISOTHERMAL SUMMER POOL COVER	COGI25
26	COPERTURA ESTIVA ISOTERMICA GALLEGGIANTE BORDATA FLOATING ISOTHERMAL SUMMER POOL COVER	COGI26
27	COPERTURA ESTIVA ISOTERMICA GALLEGGIANTE BORDATA FLOATING ISOTHERMAL SUMMER POOL COVER	COGI27
46	COPERTURA ESTIVA ISOTERMICA GALLEGGIANTE BORDATA FLOATING ISOTHERMAL SUMMER POOL COVER	COGI46
47	COPERTURA ESTIVA ISOTERMICA GALLEGGIANTE BORDATA FLOATING ISOTHERMAL SUMMER POOL COVER	COGI47
49	COPERTURA ESTIVA ISOTERMICA GALLEGGIANTE BORDATA FLOATING ISOTHERMAL SUMMER POOL COVER	COGI49
510	COPERTURA ESTIVA ISOTERMICA GALLEGGIANTE BORDATA FLOATING ISOTHERMAL SUMMER POOL COVER	COGI510
511	COPERTURA ESTIVA ISOTERMICA GALLEGGIANTE BORDATA FLOATING ISOTHERMAL SUMMER POOL COVER	COGI511
612	COPERTURA ESTIVA ISOTERMICA GALLEGGIANTE BORDATA FLOATING ISOTHERMAL SUMMER POOL COVER	COGI612



> PESI E MISURE

> WEIGHTS & SIZES

MODELLO MOD.	IMPIANTO DI FILTRAZIONE FILTERING SYSTEM	CODICE CODE	BANCALE cm. PALLET	PESO Kg WEIGHT	N. BANCALI PALLET N°
24 POP! CRYSTAL POP!	1 SKIMMER 6 M ³ H SAND FILTERING SYSTEM	KITPOP24...S6 KITCRYS24...S6	100 x 140 x 125 h	184	1
	1 SKIMMER 10 M ³ H SAND FILTERING SYSTEM	KITPOP24...S	100 x 140 x 160 h	195	1
25 POP! CRYSTAL POP!	1 SKIMMER 6 M ³ H SAND FILTERING SYSTEM	KITPOP25...S6 KITCRYS25...S6	100 x 140 x 130 h	205	1
	1 SKIMMER 10 M ³ H SAND FILTERING SYSTEM	KITPOP25...S	100 x 140 x 150 h	215	1
26 POP!	1 SKIMMER 6 M ³ H SAND FILTERING SYSTEM	KITPOP26...S6	100 x 140 x 160 h	224	1
	1 SKIMMER 10 M ³ H SAND FILTERING SYSTEM	KITPOP26...S	100 x 140 x 160 h	240	1
27 POP!	1 SKIMMER 10 M ³ H SAND FILTERING SYSTEM	KITPOP27...S	100 x 140 x 160 h	258	1
46 POP!	1 SKIMMER 10 M ³ H SAND FILTERING SYSTEM	KITPOP46...S	100 x 140 x 160 h	262	1
47 POP!	1 SKIMMER 10 M ³ H SAND FILTERING SYSTEM	KITPOP47...S	100 x 140 x 170 h	287	1
49 POP!	2 SKIMMERS 15 M ³ H SAND FILTERING SYSTEM	KITPOP49...GS	100 x 140 x 180 h	335	1
510 POP!	2 SKIMMERS 15 M ³ H SAND FILTERING SYSTEM	KITPOP510...GS	120 x 140 x 180 h	402	1
511 POP!	2 SKIMMERS 15 M ³ H SAND FILTERING SYSTEM	KITPOP511...GS	120 x 140 x 180 h	420	1
612 POP!	2 SKIMMERS 15 M ³ H SAND FILTERING SYSTEM	KITPOP612...GS	120 x 140 x 180 h	480	1

NOTA: I pesi e le misure "sabbia" riportati in questa pagina si riferiscono ai filtri a sabbia con valvola top.
NOTE: All the weights and sizes for sand filter pools kit are related to top-valve models.

> ALLEGATI TECNICI

> TECHNICAL DRAWINGS

POSIZIONE STANDARD ACCESSORI - SKIMMER, MANDATA E FARO A LED STANDARD ACCESSORIES POSITION - SKIMMER, INLET AND LIGHT

POP! CRYSTAL POP!

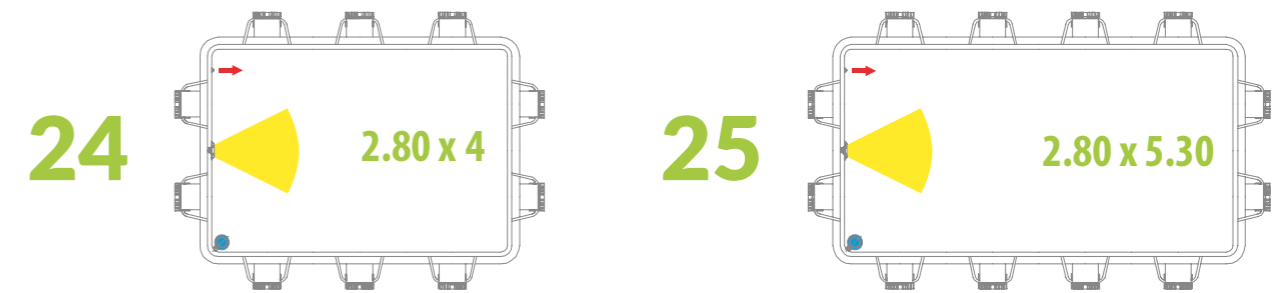

POP!

26

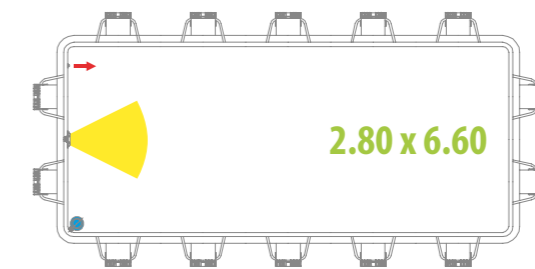

27



46

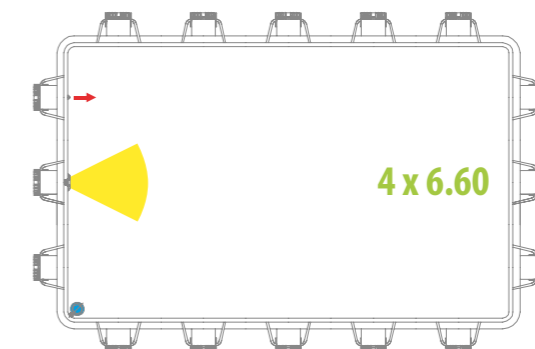

POSIZIONE STANDARD ACCESSORI - SKIMMER, MANDATA E FARO A LED
STANDARD ACCESSORIES POSITION - SKIMMER, INLET AND LIGHT

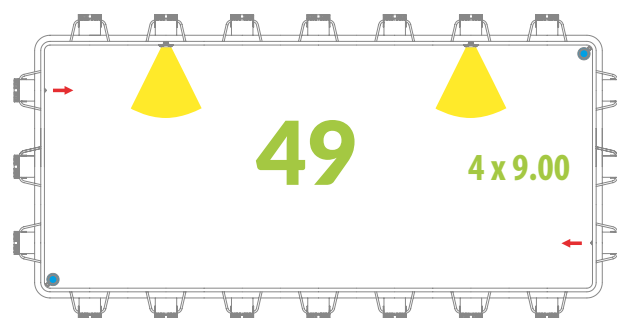
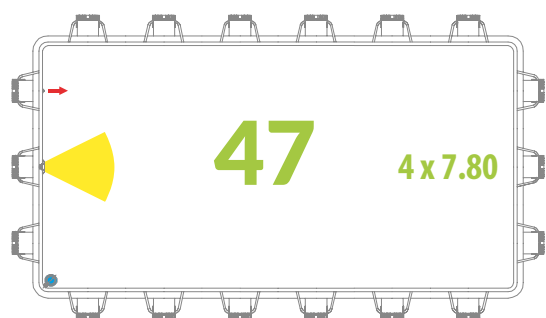

510



511

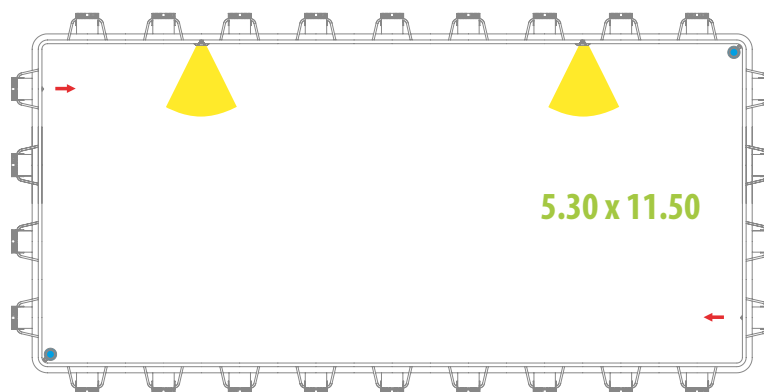

612

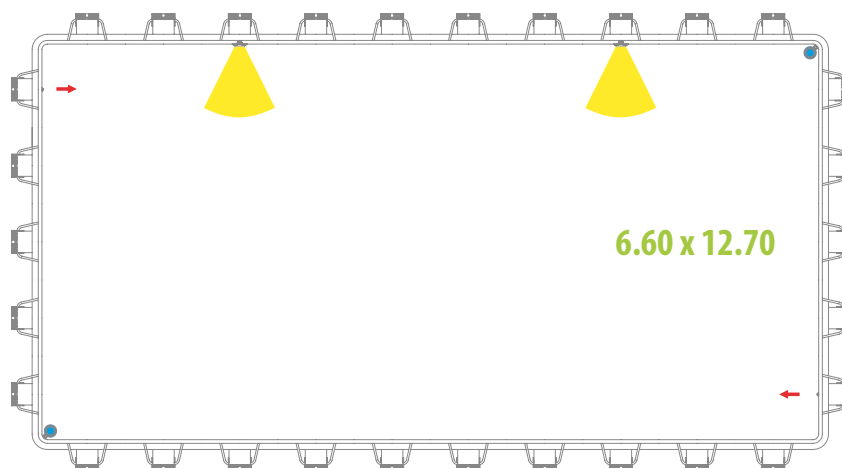



PISCINE
LAGHETTO[®]

POP!

PISCINE **LAGHETTO**[®] a FLUIDRA company